



# SmartTWO™

Installation Guide



# IMPORTANT

Split Phase 120/240 VAC Supply or 3 phase 120/208 VAC C (must be protected by a 40 A fuse or circuit breaker) Both lines must have 120V between ground.

Voltage supply must be grounded.

Require 2 lines and 1 ground connection. Neutral is not used. (Refer to Figure 1 and Figure 2).

Maximum output power: 7.2 kW @ 240 VAC or 6.3 KW @ 208 VAC

Built-in protection against overvoltage conditions and leakage current to ground

Connect the power supply of the EVSE with caliber 2 to 8 copper or aluminium conductors

Any EVSE part alteration will automatically void the warranty.

Install the Communication Gateway prior to the Commissioning of the Station

The Communication Gateway is the property of AddÉnergie. Fees will be charged if the Gateway is damaged or lost.

## IMPORTANT ELEMENTS TO CONSIDER WHEN INSTALLING THE COMMUNICATION GATEWAY:

- An Outdoor installation is recommended. The Customer must provide a waterproof PVC box and install it less than 50 meters (164 ft.) from the stations.
- Never use a GFCI outlet to power the Communication Gateway.

Contact us when the Communication Gateway is installed to validate the signal levels and activate Commissioning or for any other questions: **1 855 543 8356**

Fig. 1

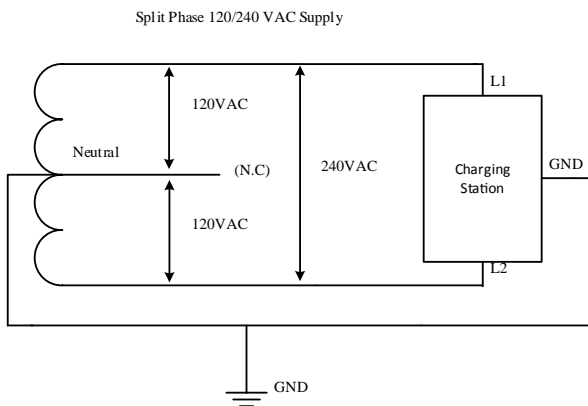
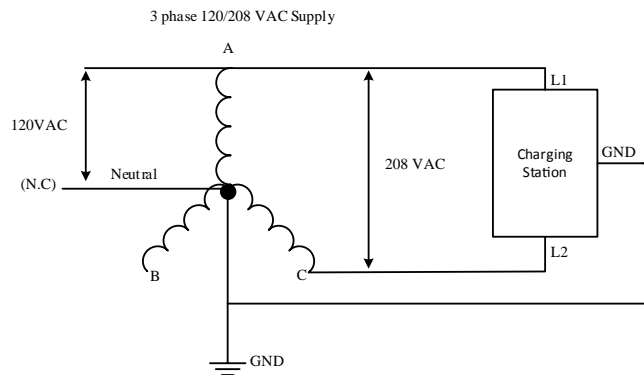
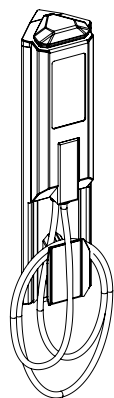

Fig. 2



## Table of Contents

Specifications .....	4
Maintenance and Safety .....	5
Configurations .....	6
Wall Mount .....	7
Connection .....	10
Front Panel and Base Cover Installation.....	11
Station Heads Installation on the Bases.....	12
Installation of the Panel on the Charging Head.....	13
Preliminary Tests and Commissioning .....	14
Copyright and Liability .....	15



Model: **SmartTWO™**

EVSE type: Level 2

Output connector: SAE J1172 compliant

Split Phase 120/240 VAC Supply or 3 phase 120/208 VAC (must be protected by a 40 A fuse or circuit breaker) Maximum output power: 7.2 kW @ 240 VAC or 6.3 kW @ 208 VAC

Built-in protection against overvoltage conditions and leakage current to ground

Ingress Protection rating: 3R enclosure type, suitable for outdoor use

Shipping weight: Approximately 30 kg for the single pedestal configuration

Patent: US 9,421,878B2

**Security standard compliance:**



- CSA C22.2 No. 0-10 General Requirements – Canadian Electrical code, part II
- CSA 281.1-12/UL2231-1 Standard for safety for personnel protection systems for electrical vehicle (EV) supply circuits: General requirements
- CSA 281.2-12/UL2231-2 Standard for safety for personnel protection systems for electric vehicle (EV) supply circuits: Particular requirements for protection devices for use in charging systems
- CSA C22.2 No. 280-13/UL2594 (1st edition) Electric vehicle supply equipment (EVSE)
- Supported communication protocols: ONP and OCPP

This product is approved by the California Type Evaluation Program

**Electrical standard compliance:** Certified ENERGY STAR® 1.2

**NOTE:** The SmartTWO-M is not certified ENERGY STAR® 1.2.

## Product Symbols

The following symbols appear on the station and in this guide:

Symbol	Description
	Alternating current
	Continuous current
	Phase
	CAUTION: This symbol is used to provide awareness of important safety information in these instructions
	WARNING: This symbol is used to provide warning of hazardous voltage and possibility of electric shock
	Earth "ground" terminal
	Protective (earth) ground Class 1
	Chassis
	Hot surface

# Maintenance and Safety

## IMPORTANT SAFETY INSTRUCTIONS - PLEASE DO NOT DISCARD THESE INSTRUCTIONS

### Carefully read this guide before installing the EVSE

1. This EVSE was designed to be wall-mounted or pole-mounted.
  - 1.1. For the wall-mounted version, you must make sure the wall on which it will be mounted is strong enough, and that you use the appropriate type of anchors.
  - 1.2. For the pole mounted version, you must make sure the pole on which it will be mounted is strong enough, and that you use the appropriate type of tether straps.
2. Make sure with local authorities that the location where the EVSE is to be installed is free from underground pipelines or electrical equipment, otherwise you might inflict yourself serious injuries.
3. Connect the power supply of the EVSE with caliber 2 to 8 copper or aluminium conductors rated for usage at a temperature of at least 75 °C.
4. Grounding: to ensure the safe operation of the AddÉnergie's EVSE, it must be connected to a grounding circuit compliant with local regulations and installed by a certified electrician.
5. Communicate with a certified contractor, certified electrician or trained installer to ensure compliance with local building code, regulation such as ADA compliance, security standards and weather conditions.
6. Any EVSE part alteration will automatically void the warranty.
7. Handle parts with care, since they can be sharp-edged. Always use safety glasses and gloves when unpacking and installing.
8. Some parts are heavy and could cause injuries. Use proper lifting techniques and wear safety boots at all times during installation.
9. Never insert your finger into the electric vehicle connection.
10. Never use the EVSE if the flexible power cord seems damaged or if insulation is damaged.
11. Never use the EVSE if the main case is broken, cracked, open or damaged.
12. This EVSE was designed to be used with electric vehicles equipped with a SAE-J1772 connector.
13. This EVSE is to be used to charge vehicles that do not require a ventilated environment during charging.
14. Replacement of the EVSE's head, gun module, gun cable, or gun must be performed by qualified service personnel.
15. When the case of the EVSE's head is open, all gaskets must be replaced.
16. Do not install on or over a combustible surface.

# Configurations

## Recommended Dimensions



### Pole-mounted EVSE

Leave a minimum of 7,6 cm (3") on top of the main structure to insert the EVSE's head.

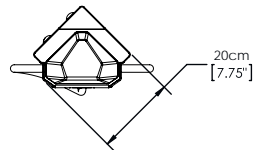
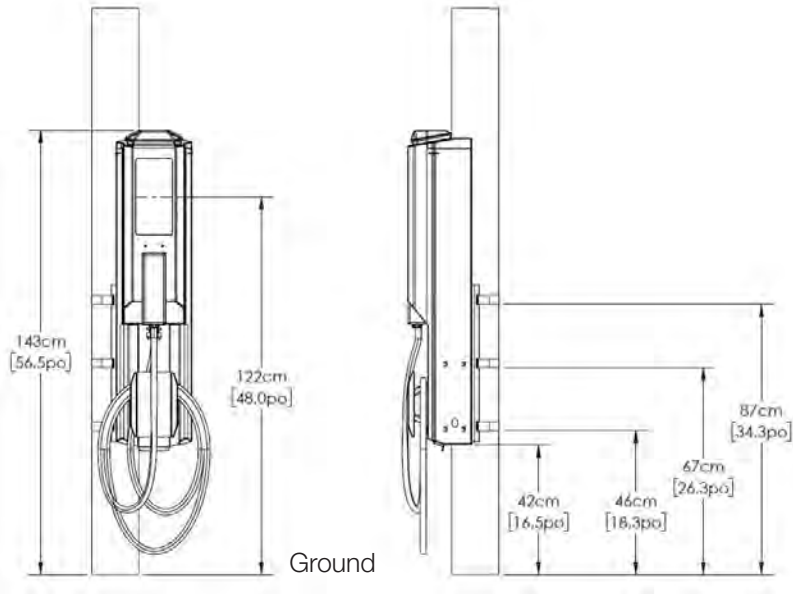

### Wall-mounted EVSE

Leave a minimum of 7,6 cm (3") on top of the main structure to insert the EVSE's head.

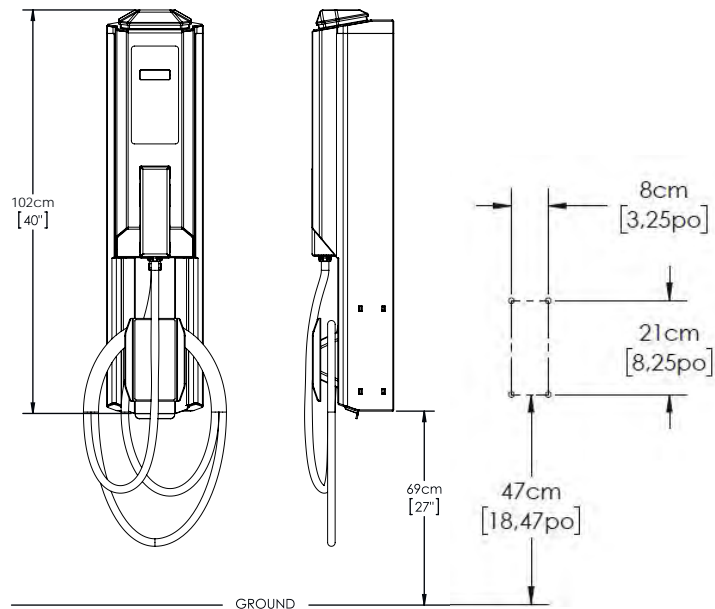

# Wall Mount

## Single Unit Installation

Nbr	Description	Qty
1	Main Structure	1
2	Front Panel	1
3	Block Cover	1

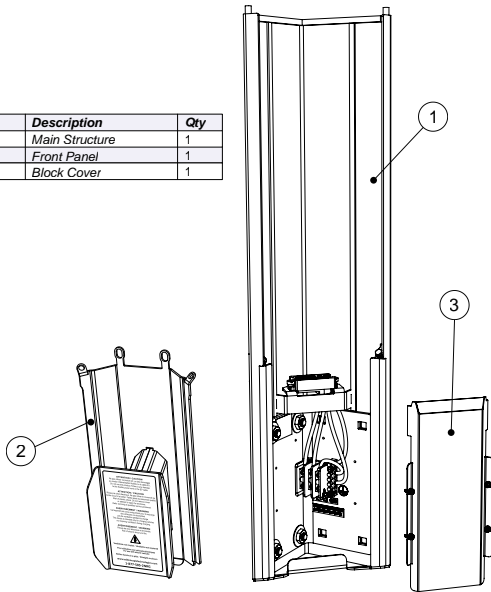

### INSTRUCTIONS:

- Make sure that the available height is a minimum of 216 cm (85")
- If the wall requires that anchors to be pre-installed, follow the drilling pattern provided on right
- Install the base on the wall using the proper type of anchors, which means 1/2-13 inserts and bolts for a concrete wall, or 1/2 lag bolts for a wooden wall.
- Before drilling and during the installation of the base on the wall, make sure that everything is leveled

Drilling pattern:

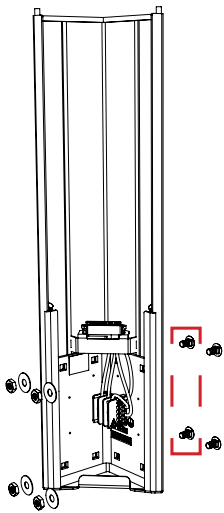
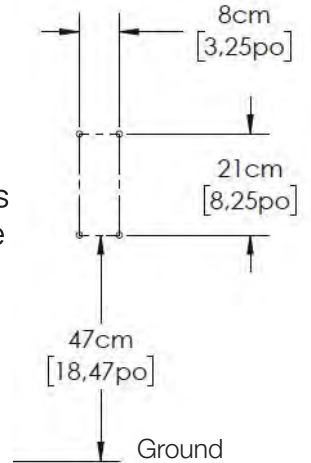

Left side mounting

### SPECIAL NOTES:

- The EVSE has been assembled at the factory to point toward the right side, assuming that it will be installed on the left corner of the parking stall.
- To install on the right corner of the parking stall, the nuts and bolts attaching the back of the base to its inner frame shall be transferred from one side to the other as shown on the pictures.
- Make sure you put both longer bolts at the position closest to the terminal block.

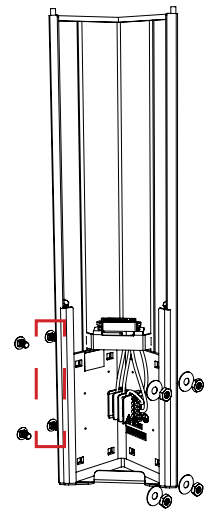

Right side mounting

# Wall Mount

## Double Unit Installation

For double mounting with panel holder (part number: S2-V2-ACCSPSM-01-02), add spacers (part number: S2-V2-ACCSPSM-01-05) between the main structures.

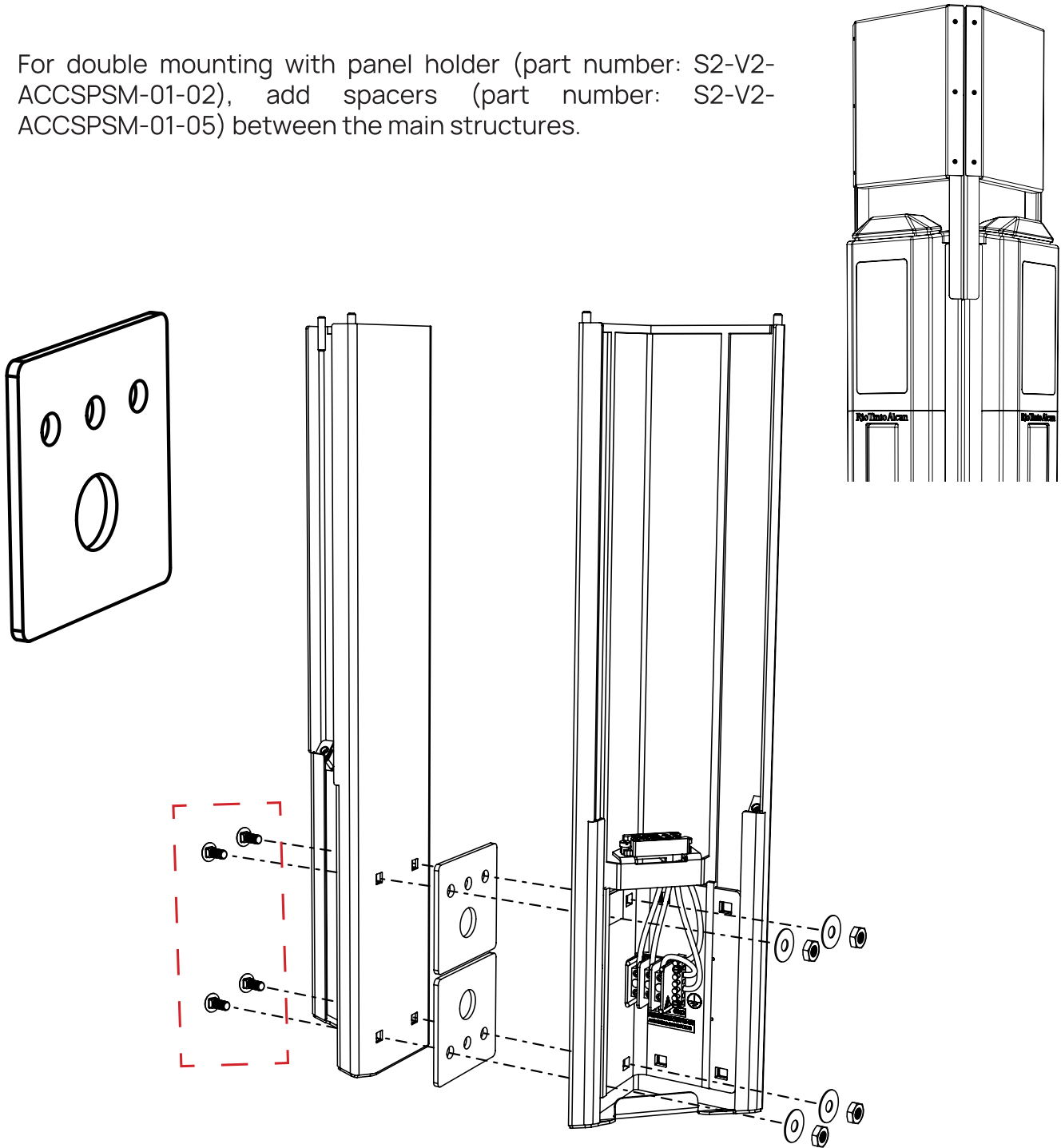

*Use longer bolts, 5.1 cm (2")*



# Wall Mount

## Double Unit Installation

### INSTRUCTIONS:

- Identify which sides of the main structure must be assembled face to face and remove their corresponding bolts and screwed plates.
- Place the main structures one against the other and join using the four (4) longest carriage bolts you just removed.

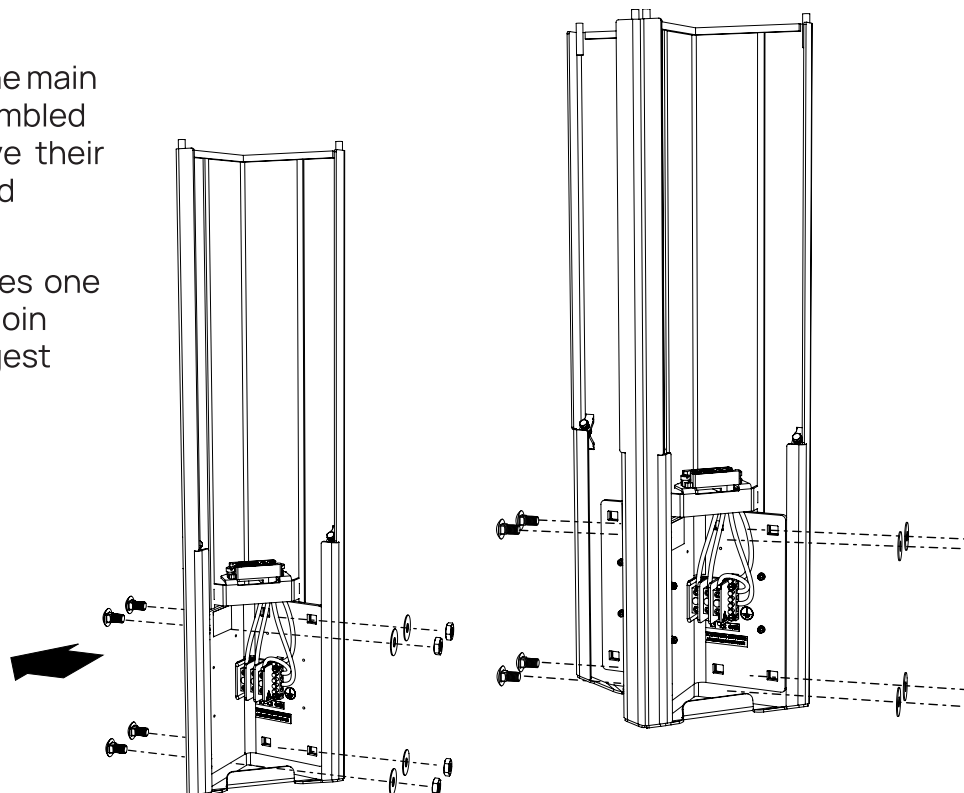

- Make sure that the available height is a minimum of 216 cm (85”).
- If the wall requires that anchors to be pre-installed, follow the drilling pattern provided on right.
- Install the base on the wall using the proper type of anchors, which means ½-13 inserts and bolts for a concrete wall, or ½ lag bolts for a wooden wall.
- Before drilling and during the installation of the base on the wall, make sure that everything is leveled.

*Drilling pattern:*

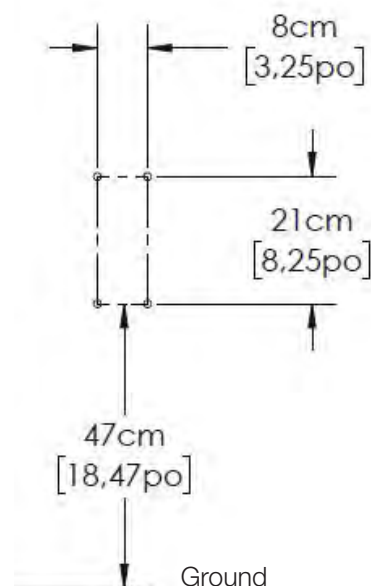

# Electrical Connections

Remove the block cover.

Insert the wires from the bottom of the base and proceed with the connection as shown on the figure below for each EVSE.

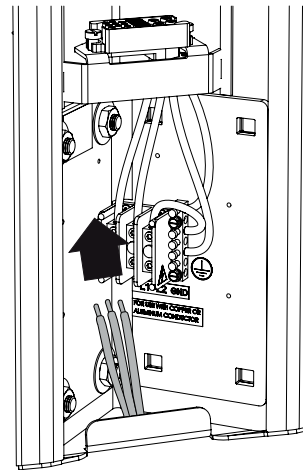
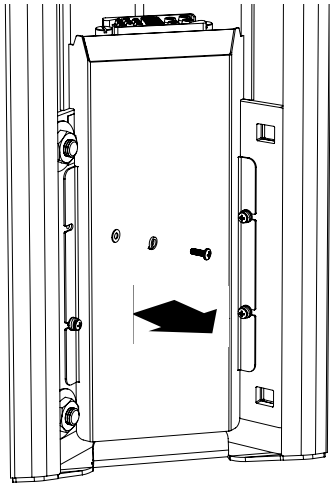

Wall-mounted



## IMPORTANT

Installation and maintenance of this EVSE must only be performed by a certified electrician to ensure compliance with local and national codes.

Requires a dedicated 40A dual protection device (breaker or fuse).

Do not add CCID protection to the service panel. This kind of protection is already built into AddÉnergie's EVSE.

Input: 208/240VAC nominal, 60Hz, 30A

Recommended tightening torque for the block bolts: 18 Nm. Wire size of AWG 2 - 8, copper or aluminium

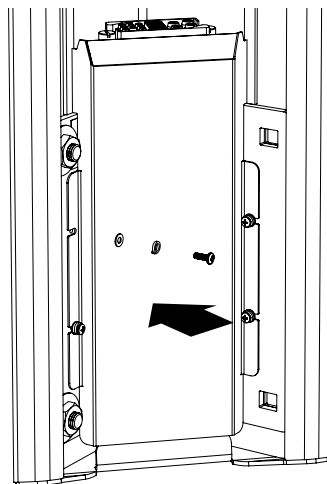
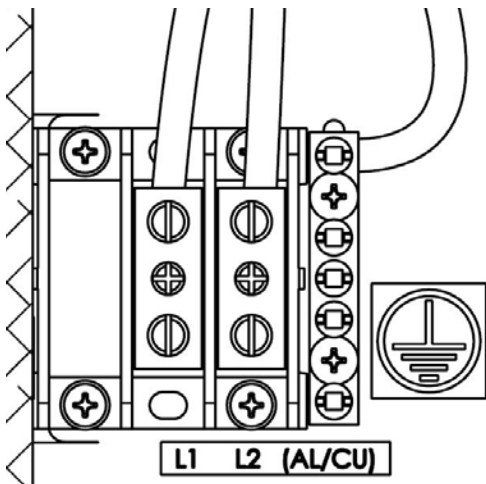

Reinstall the block cover once all connections are made.

# Front Panel & Base Cover Installation

## INSTRUCTIONS:

1. Slide the front panels into each of the main structures.
2. Fasten each front panel's two mounting brackets with bolts and star washers.

Step 1

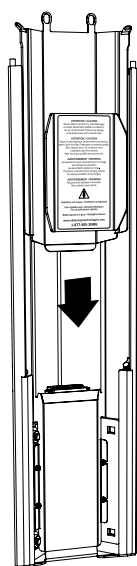

Step 2

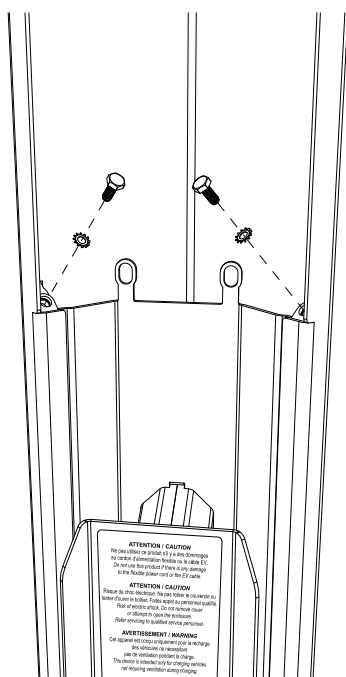

# Station Head and Connector Installation

## Installation of the Charging Station Head on its Base

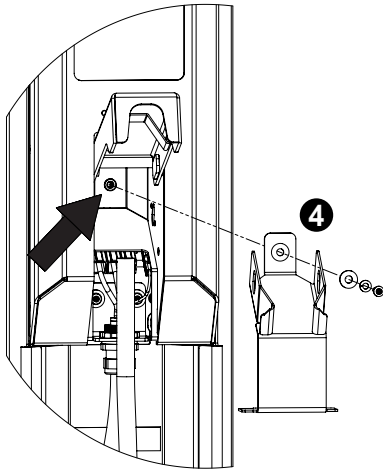

1. Unscrew the charging port holder **4**.
2. Remove the charging port and cable assembly
  - 2.1 Disconnect the three positions connector **2** and the small black connector **3**.
  - 2.2 Unscrew the two brackets **1**.
3. Slide the head into the base

### Important:

- Do not slide the head down with excessive force. If the head doesn't slide down into position easily, gently shake the base of the charger head while guiding it into the base.
- Be careful not to damage the black plastic connectors on the bottom of the charger head on the top of the base.
- Once fully inserted, the spacing between the head and the base should be from 0 à 3mm.

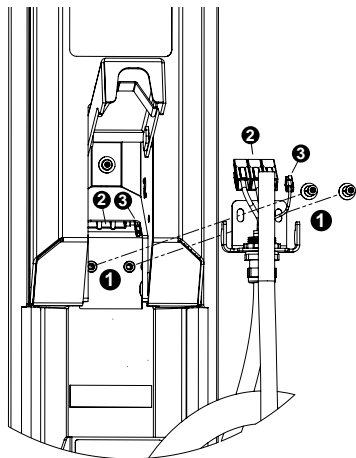
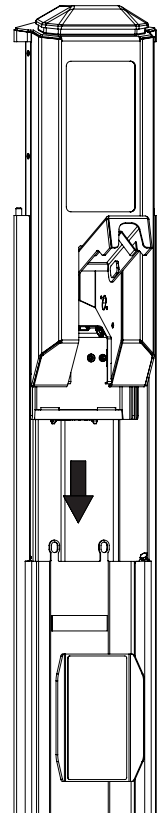

## Installation of the Charging Coupling Connector

1. Screw the bracket back into place **1**.
2. Connect the three positions connector **2** (green connection should be on the right) and the small black connector **3**.
3. Screw the charging port holder back into place **4**.

Make sure the bottom of the charging port holder does not interfere with the base.

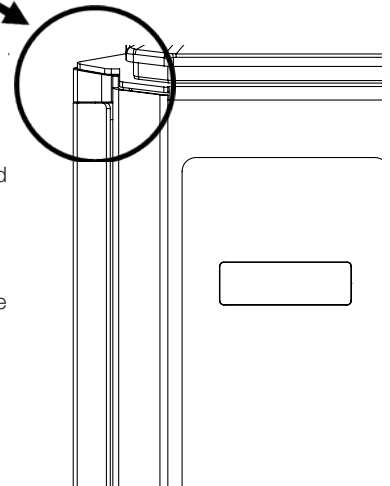

\* **WARNING:** Never use a power tool to install the security screws, and never apply a torque of more than 18 Nm (160 pound-inches) when tightening them.

# Installation of the Panel on the Charging Head

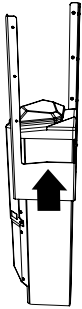

- Slide the panel holder onto the charging station head as shown in the image on the left (at this stage, the panel holder is not attached to the head but simply clipped to it).
- Attach the panel(s) to the panel holder. Only one is required for a wall mount installation and two are required for a pedestal installation.
- For a double or quadruple installation screw the adjacent panel holders together, as shown on the image to the right.

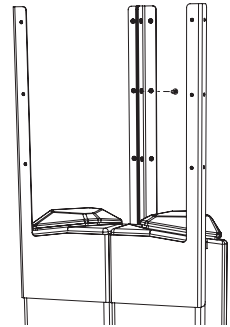

## WALL MOUNT

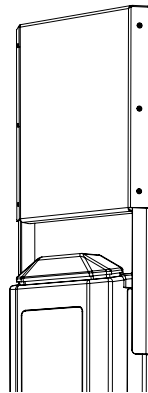

*Single  
(1 panel)*

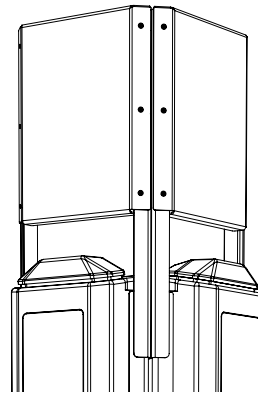

*Double  
(2 panels)*

# Preliminary Tests and Commissioning

**IMPORTANT:** The commissioning might need to be conducted by an authorized Division of Measurement Standards (DMS) agent if this charging station is intended for use in energy billing mode under commercial application in California. Please call FLO Services for more details.

## Instructions:

1. Place the charging port in the holder and close the door. **1 2**
2. Once the charging station is powered up, check the following:
  - 2.1. The door is locked.
  - 2.2. The charger head status lights turn to GREEN.
  - 2.3. The display shows the greeting messages.

3. Swipe the card provided with the charger in front of the display. **3**

The charger will react as follows:

- 3.1. Once the reader detects the card, it will emit an audible beep.
- 3.2. The access card is authenticated by the charging station.
- 3.3. If the test is successful, the charger head status WHITE lights will start flashing and the charging port will be unlocked. **4**
- 3.4. If the charging port is inserted into an Electrical Vehicle, it will begin charging. If not, 1 minute later, the charging session will be cancelled.

4. If the preliminary test is successful:
  - 4.1. Make sure you have installed the Communication Gateway according to the instructions described in the "Important" section, on page 2 of this guide.
  - 4.2. Call FLO for charger commissioning:

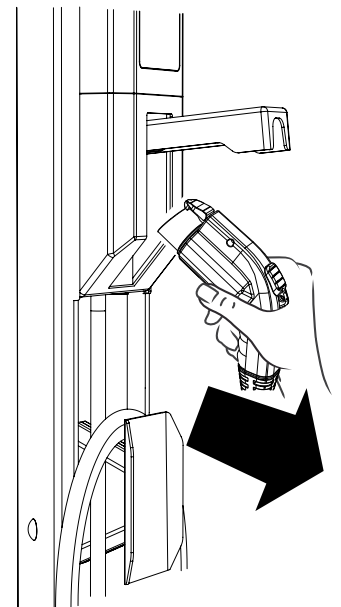
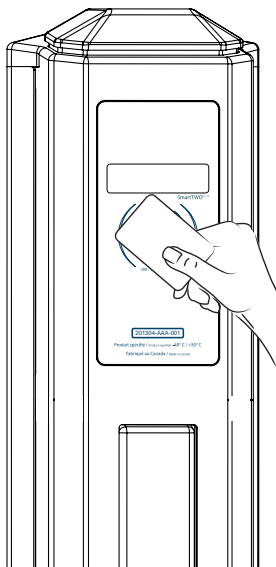
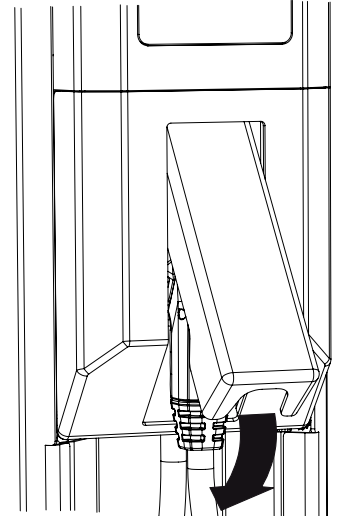
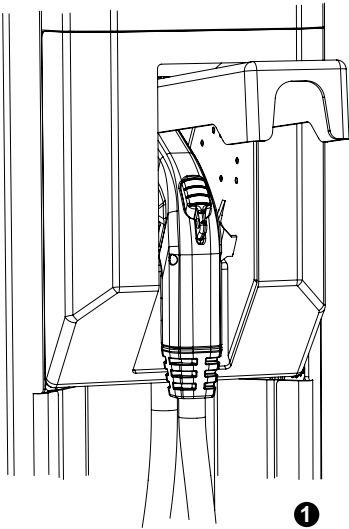

1 855 543 8356



# Copyright and Liability

**Document name:** FLO\_SmartTWO\_Installation-Guide\_V.21.0.1\_2024-09-24\_US\_EN

**Document ID:** PRFM0099

**FLO US:** © 2022-2024 FLO Services USA Inc. All rights reserved. FLO, the FLO logo, LEAD THE WAY, and TRACEZ LA VOIE are trademarks of Services FLO Inc. used under license by FLO Services USA Inc. ADDÉNERGIE is a trademark of AddÉnergie Technologies Inc. used under license by FLO Services USA Inc.

This document is provided as a general instruction guide. All pictures shown are for illustration purposes only. Actual stations may vary in size or due to product enhancements, in which case additional steps may be required. AddÉnergie Technologies Inc. and its subsidiaries ("AddÉnergie") reserve the right to alter this document and any product offerings and specifications at any time without notice and AddÉnergie does not guarantee that that this version of the document is current. It is your responsibility to comply with all applicable laws, including those related to accessibility, zoning, and to exercise due diligence when conducting an installation or using this product. Careless installation or use may result in injury or product damage. To fullest extent permitted by applicable laws, AddÉnergie disclaims any liability for personal injury or property damage resulting from the installation or use of this product.

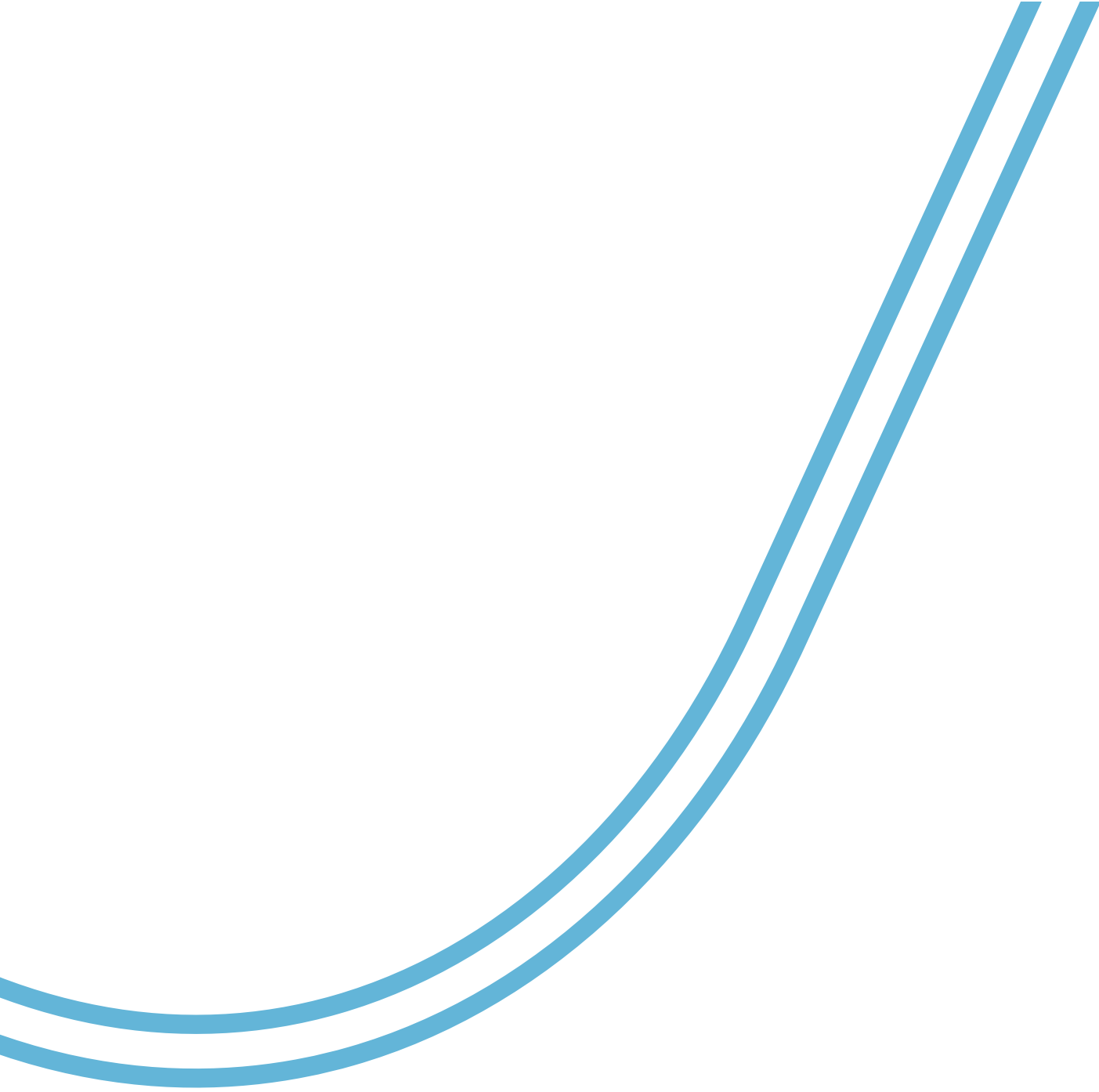

**Learn more**

[info@flo.com](mailto:info@flo.com)

1 (855) 543-8356

[flo.com](http://flo.com)

Eastern office: 2800, Louis-Lumière Street, office 100, Québec (QC) G1P 0A4 CANADA

Regional office – Western Canada: #501 – 4190 Lougheed Highway Burnaby (British Columbia), Canada, V5C 6A8

United-States office: 1270 Pacific Dr, Auburn Hills, MI, United States – 48326