



Shown with optional cable management system

CoRe+™

Smart level 2 charging station for private, public and commercial applications

The CoRe+™ charging station is designed for applications such as workplaces, multi-unit residential buildings, fleets, and is also suitable for public spaces

Easy to use and reliable

- Cable management system (CMS) with unique counterweight system for smooth retraction.¹
- Built to last with rugged Type 4X aluminum enclosure to protect the station from windblown dust, debris, ice and water
- Integrated cable holster for neat, safe cable storage

Versatile and efficient

- Save on electricity costs with patented PowerSharing™ and PowerLimiting™ technologies.
- Customizable installation choices suit a variety of parking configurations.

Smart station, smarter investment

- Monitor station health and gain key insights with the cloud-based management dashboard.
- Maximize uptime with proactive station monitoring and remote intervention services.²
- Easily expand capacity with optional cascading kit to daisy-chain multiple charging stations on the same branch circuit



For workplace

Offer EV charging services to your employees, with a solution that will evolve with you as more drivers make the switch to electric vehicles.

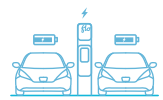

For fleets

Ideal for fleet managers who wish to grow their light and medium duty EV fleets while maintaining affordable operational costs.

¹ Optional

² Requires FLO Global Management Services (GMS)

Available Configurations



DIMENSIONS

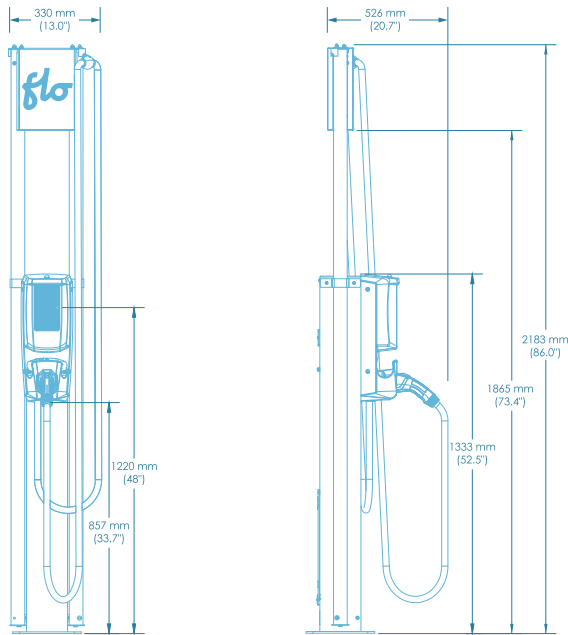

Single CoRe+™ on pedestal with CMS

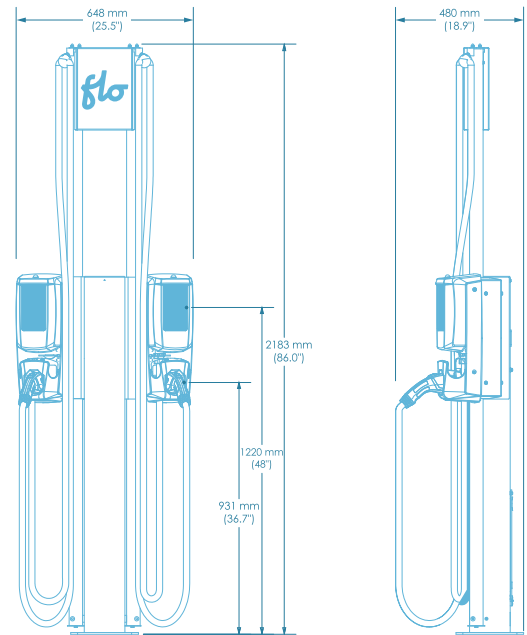

Dual side-by-side CoRe+™ on pedestal with CMS

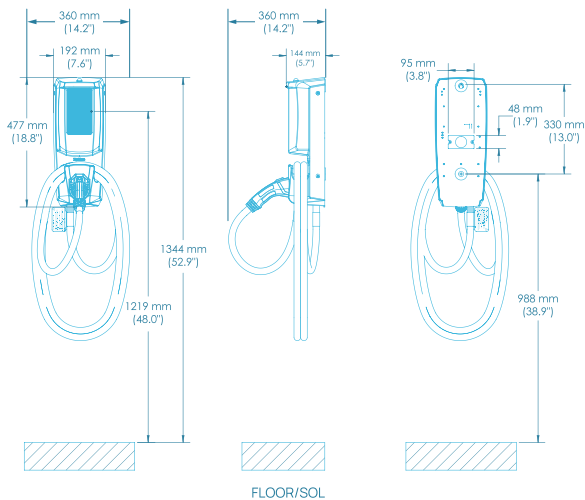

Wall Mount CoRe+™ (without CMS)

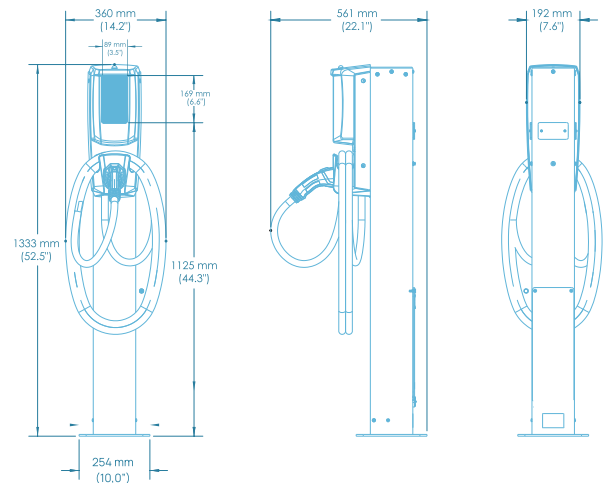

Single CoRe+™ on pedestal (without CMS)

Technical specifications

HARDWARE

Enclosure	Aluminum Type 4X
Charging Connector	SAE J1772
Cable Length	6.4 m / 21 ft
Cable Management System (optional)	6.4 m / 21 ft - Calibrated suspended weight
Operating and storage temperature	-40 °F to 122 °F / -40 °C to 50 °C
Weight	Charging station: 9.5 kg / 21 lbs Pedestal: 14.5 kg / 32 lbs CMS: 6.8 kg / 15 lbs
Humidity	Up to 95% (non-condensing)

ELECTRICAL

Electrical load	208 VAC or 240 VAC for each charging station
Charging Power	1.2 - 7.2 kW (maximum configurable by software)
Output Current	6 A to 30 A (maximum configurable software)
Integrated GFCI	20 mA, auto reset (3 attempts at 15-minute intervals)
Frequency	60 Hz

INTERFACE

Card reader	ISO 14443 A/B, ISO 15693
-------------	--------------------------

CONNECTIVITY

Communication Interface	ZigBee - IEEE 802.15.4 meshed network
Cellular Communication	Cellular - 4G/LTE (gateway installed separately)

CERTIFICATIONS AND COMPLIANCE

ENERGY STAR	YES
EMI Compliance	CSA- C22.2 No. 280, UL 2594, CSA C22.2 No 281.1 and 281.2, UL 2231-1 and 2231-2, UL Listed CAN - ICES-003 (A); ADA Compliant
EMC Compliance	USA - FCC 47 CFR part 15 class A, CAN - ICES-003 (A)
Metering Accuracy	Certified according to California Type Evaluation Program (CTEP)



Learn more
info@flo.com
1 (855) 543-8356
flo.com



Made in North America

Designed and manufactured
by AddÉnergie Technologies Inc. d/b/a FLO.
flo-core+-specsheat-en-d-2025-01-23